

AB Fieldstone[®]

by Allan Block



allanblock.com



*The Look and
Feel of
Natural Stone*



allanblock.com



*Introducing the first Eco-Friendly mortarless concrete retaining wall system –
AB Fieldstone Collection.*

This innovative new product has unlimited possibilities in style and constructibility. It is right at home in residential settings or up for any task on commercial projects.

AB Fieldstone is an innovative new concept in the manufacture and use of segmental retaining wall (SRW) systems. By manufacturing this system in 2 pieces - the facing unit and the anchoring unit, Allan Block has opened the door to many benefits that are not only **Green**, but **Natural** and **Friendly** as well.

AB Fieldstone Collection®

The look of natural stone that's easier to install and at a fraction of the cost.

AB Fieldstone comes as close as you can get to matching the raw beauty of natural stone. The facing units are created with differing textures and colors to emulate natural stone. Each look is referred to as a Series. There are currently four to choose from: Sierra, Cascade, Colonial and Heritage, with additional ones in development.

Choose any one of the Series and they are sure to provide a timeless elegance to any surrounding.

Check out allanblock.com for all the latest information.



The AB Fieldstone product is made with recycled materials. Using recycled materials has allowed us to create a "green" retaining wall system that is safe for the environment without taking away from the quality of the blocks.

There are 14 different LEED® credits that can be achieved.



Short Anchoring Unit (SAU)

812 Facing Unit



Why Choose to use AB Fieldstone

- Has the look and feel of natural stone
- Easier to install than natural stone
- Fraction of the cost of natural stone
- The two-piece system is lighter in weight than natural stone
- Build taller walls without geogrid
- Built-in corner blocks
- Facing units can be rotated for additional looks and styles
- Retaining walls and parapet walls all with one product line
- Every block is the exact same height
- Environmentally friendly product
- Series faces can be blended together for more unique styles



allanblock.com

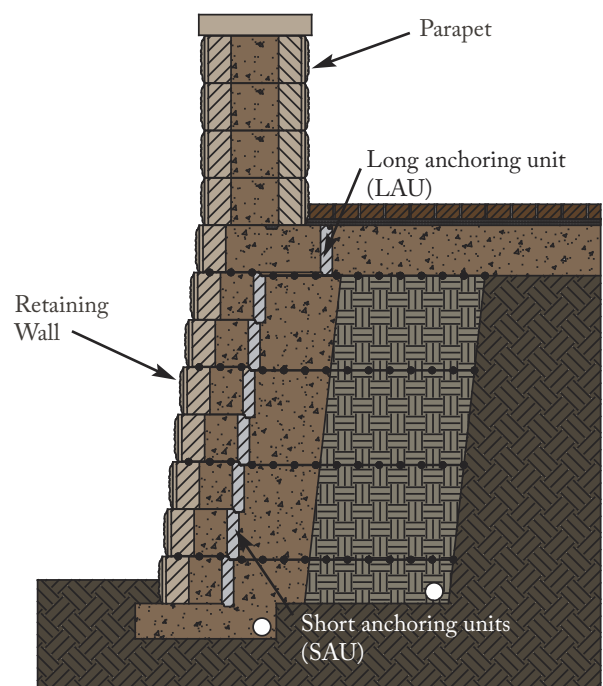

allanblock.com



AB Fieldstone is a two-piece system with interchangeable facing units and anchoring units. The facing units come in 2 sizes - 812 and 824. They can be used individually or mixed together in the project. There is no top or bottom for the facing units, so flipping them over, adds an even more random style, creating a natural stone look.

The anchoring units also come in 2 sizes, compatible with both facing unit sizes and are made out of recycled materials. The short anchoring units (SAU) make a block that is 12 in. (300 mm) deep and the long anchoring units (LAU) make a block that is 24 in. (600 mm) deep making them ideal for taller walls with no added reinforcement.

812 facing units with SAU & LAU*



824 facing unit with SAU & LAU



** One in every four 812 facing units is a corner unit.*



Heritage Series



*Colonial &
Sierra Series*

*Retaining Walls
with Parapets
One System,
One Product*



Sierra Series

*Residential or Commercial
AB Fieldstone has
the Wall Solution*

Sierra Series



*Colonial &
Sierra Series*



*Quality
Products with
an Aesthetic
Appeal*



*The Many
Faces of
AB Fieldstone*

Cascade Series



Sierra Series



*Colonial &
Sierra Series*



Sierra Series

*The Look
and Feel of
Natural Stone*



Sierra Series



*Modular,
Versatile and
Environmentally
Friendly*



Colonial Series



Heritage Series

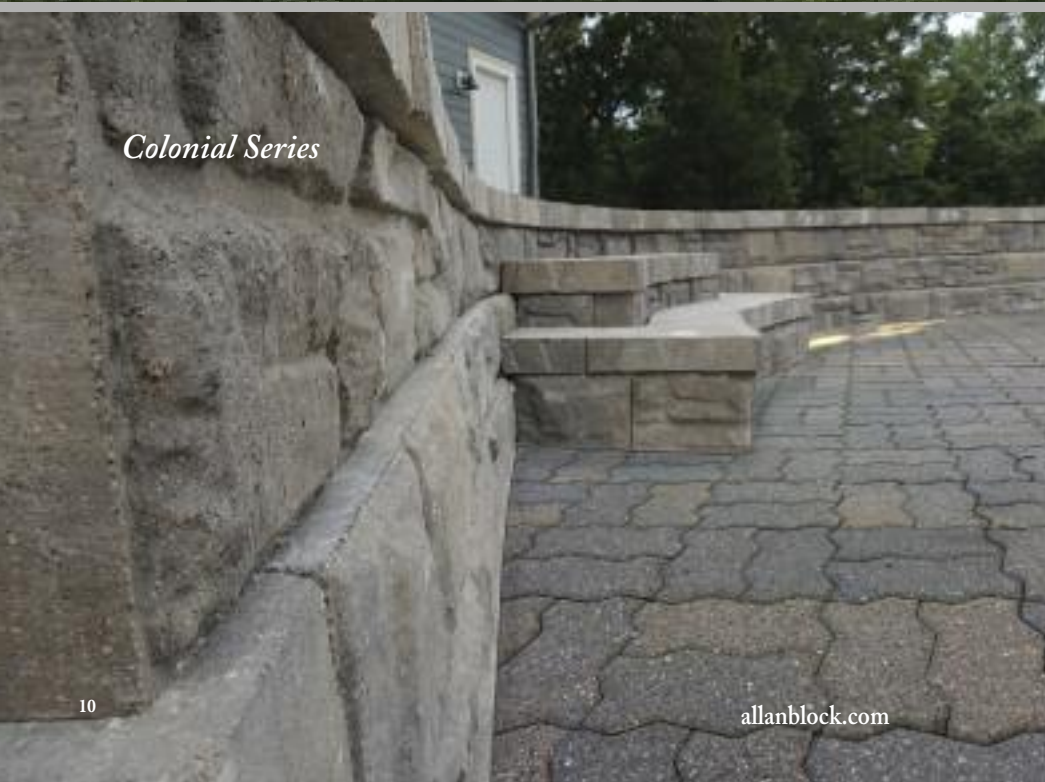

Colonial Series

*A Fraction of
the Cost of
Natural Stone*



*Simple and
Easy
to Install*





Colonial Series



*Adding
Definition
and
Character to
the Outdoors*



Colonial Series

*Durable Beauty
with an
Authentic Look
of Nature*



Sierra Series

Details and Applications

AB Fieldstone is a very versatile product that can be used for retaining walls as well as free standing parapets. There are many different details and applications. Here we detail a few of the different ways it can work for any project or create the solution for any landscape.



Colonial and Sierra Series used together

Multiple Faces



AB Fieldstone is unique in the fact that it offers four different facing units - Series. Each of these Series come in 812 and 824. They can be used individually or blended together in projects to create more unique looks and styles.

See pages 4-13 to see the many faces of AB Fieldstone.



With the AB Fieldstone's long anchoring units (LAU) a retaining wall project can now be built to new heights without the need for geogrid reinforcement. Using the long anchoring units (LAU) will also make it easier to build many other applications like stairs, fence railings, and under upper walls that branch off from lower walls to name a few.

See page 16-17 for more information.

Design Elements



Finishing or stepping down a wall is easily done using the 812 corner facing units. By placing the corner unit at the end of each course, perpendicular to the wall as it steps down, it creates a finished end.

Place caps or cut caps at 45° to complete the course with a finished look.

See page 20 for more information.

Step Downs



Stairways are a design element that give access to the upper levels of the landscape and helps soften the look of a retaining wall.

With AB Fieldstone, stairways can easily be constructed using the long anchoring units (LAU). The anchoring units provide a level and stable surface to build on, making it easy to build up the slope with additional steps.

See page 21 for more information.



Stairways

Free standing two-sided walls or parapets are easy to integrate into a project or built to standalone on an existing structure. By placing the facing units back to back with the AB Dogbone unit, a parapet can be built to any width.

Use the same product for a retaining wall with a parapet wall on top to create a seamless transition.

See page 22-24 for more information.



Parapets

Some of the 812 facing units can be used as corner blocks. This unit offers a textured return side. They can be used within the wall or as a corner block.

For every 4 facing units there is 1 corner unit. Look for them and set them aside if there are corners on the project.

See page 19 for more information.



Corners

Installation Basics

Building with AB Fieldstone

Installing AB Fieldstone's two-piece system is quick and easy. On a prepared base, install and level the facing units the length of the wall, then install all the anchoring units by sliding them together. On additional courses the rear lip on the back of the anchoring unit locks the blocks together. Block cores and behind the blocks are then filled with wall rock per the full installation instruction. See the AB Installation manuals at allanblock.com.

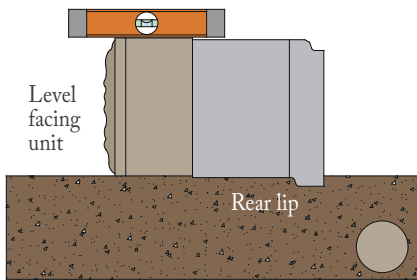

The anchoring units should never be installed higher than the facing unit and should be reasonably level.

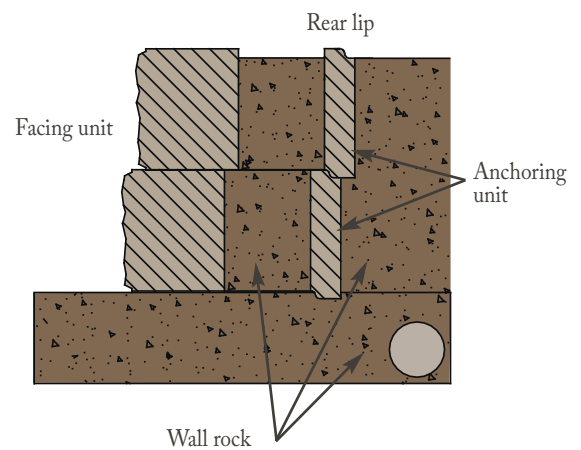
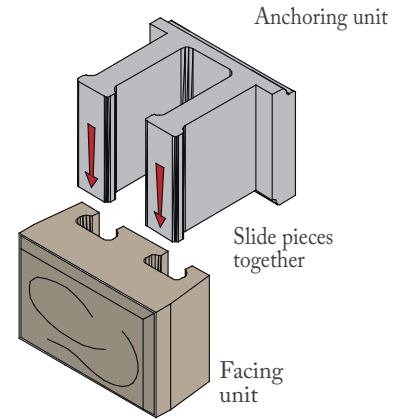

Gravity Walls

Taller gravity walls can be achieved using the long anchoring units. This eliminates the need for geogrid reinforcement. Use the Maximum Gravity Wall Heights table to check the maximum wall height of the project before needing reinforcement.

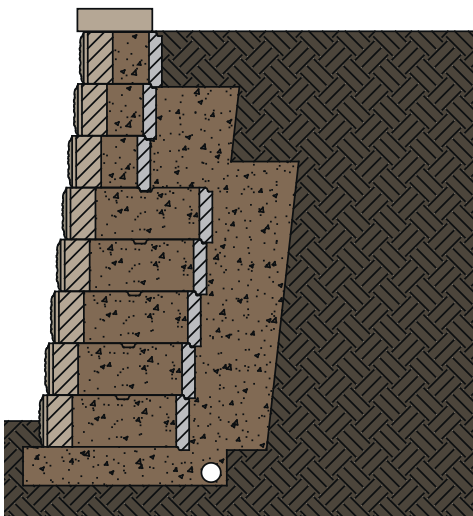

Reinforced Walls

AB Fieldstone can be built using the short anchoring units with geogrid when reinforcement is needed. Check the Maximum Gravity Wall Heights table and the Soil Reinforcement table for proper geogrid placement.

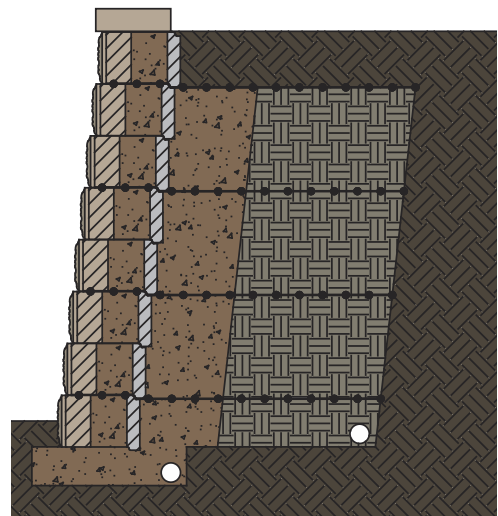

Anchoring Units

The long (LAU) and short (SAU) anchoring unit can be used together to build the wall or to finish off the top of taller gravity walls. Some of the long anchoring units allow for placement of the rear lip of a SAU with a built in notch. For every 2 units, 1 will have a notch. If combining the anchoring units on a project, look for these and use accordingly.

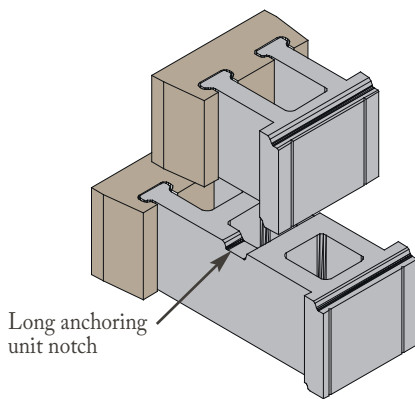

Example

A 6 ft high wall (1.8 m) with short anchoring units (SAU), built in sandy soil with a level surface above the wall will require geogrid - four layers, 4 ft wide (1.2 m). If using long anchoring units (LAU), it will require no additional reinforcement, but will require review by a local professional engineer.

Maximum Wall Heights AB Gravity Walls

Condition above retaining wall	Soil Type	Friction Angle	6° (Ref)	
			AB Fieldstone Short Anchoring Unit (SAU)	AB Fieldstone Long Anchoring Unit (LAU)
Level	Clay	27°	3 ft. 7 in. 1.1 m	5 ft. 10 in. 1.8 m
	Silty Sand	32°	5.0 ft. 1.5 m	8 ft. 6 in. 2.6 m
	Sand/Gravel	36°	5 ft. 8 in. 1.7 m	9 ft. 8 in. 3.0 m
Surcharge* 100 psf (4.7 kPa)	Clay	27°	1 ft. 8 in. 0.5 m	4.0 ft. 1.2 m
	Silty Sand	32°	3 ft. 7 in. 1.1 m	7.0 ft. 2.1 m
	Sand/Gravel	36°	4 ft. 2 in. 1.3 m	8.0 ft. 2.4 m
Slope 3:1	Clay	27°	2 ft. 8 in. 0.8 m	4 ft. 4 in. 1.3 m
	Silty Sand	32°	4 ft. 4 in. 1.3 m	7 ft. 4 in. 2.3 m
	Sand/Gravel	36°	5 ft. 1 in. 1.5 m	8 ft. 7 in. 2.6 m

Table is based on clay soil having an internal friction angle of 27° (Ref) or better and a sandy soil having an internal friction angle of 32° (Ref) or better and a sand/gravel soils having an internal friction angle of 36° (Ref) or better. All heights based on exposed wall heights and include a cap block. The gravity wall heights shown above do not account for seismic loading. Check with a local engineer for assistance if you are in a seismic area. Final designs for construction purposes must be performed by a local registered professional engineer, using the actual conditions of the proposed site. *The surcharge loading category above assumes a solid surface such as concrete, asphalt or pavers having a suitable supporting subgrade.

Soil Reinforcement Chart for Residential Wall Applications

CONDITION ABOVE WALL	WALL HEIGHT**	AB Fieldstone Collection			
		CLAY SOIL		SANDY SOIL	
		No. of Layers	Width (W)	No. of Layers	Width (W)
Level	3ft (0.9 m)	0	0	0	0
	4ft (1.2 m)	2	3 ft	0	0
	5ft (1.5 m)	3	4 ft	3	3 ft
	6ft (1.8 m)	4	4 ft	4	4 ft
Surcharge* 100 psf (4.7 kPa)	2ft (0.6 m)	1	3 ft	0	0
	3ft (0.9 m)	2	3 ft	0	0
	4ft (1.2 m)	2	3 ft	2	3 ft
	5ft (1.5 m)	3	3 ft	3	3 ft
Slope 3:1	3ft (0.9 m)	2	3 ft	0	0
	4ft (1.2 m)	2	3 ft	2	3 ft
	5ft (1.5 m)	3	4 ft	3	3 ft
	6ft (1.8 m)	4	4 ft	4	4 ft

Table is based on clay soil having an internal friction angle of 27° (Ref) or better and a sandy soil having an internal friction angle of 32° (Ref) or better. Soil reinforcement increases the strength of the wall by creating a reinforced mass of soil behind the blocks. The weight of the reinforced soil mass combines with the blocks for a heavier, stronger wall. Table is for estimating geogrid quantities only. For walls in the surcharge loading category above, on the last (top) layer of geogrid, it is typical to lengthen this grid by an additional 2 ft (600 mm). To achieve these longer grid lengths, the Allan Block reinforcing grid must be installed perpendicular to the wall (rolled out from the front of the block to the back of the excavated area). *The surcharge loading category above assumes a solid surface such as concrete, asphalt or pavers having a suitable supporting subgrade. ** Wall heights are for reference only.

Installation Basics

Building with Curves

Curved and serpentine walls are simple to build and allow installation of both inside and outside curves. Most curves can be built with no cutting involved.



Inside Curves

On inside curves, place the facing units to form the curve. Keep the front of the blocks tight together.

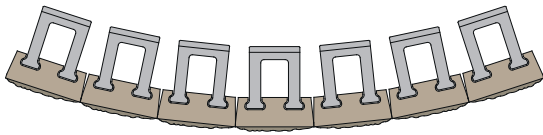

Outside Curves

On outside curves, remove one or both of the wings from the short anchoring unit (SAU) to form the curve desired. Use the Radius Chart to determine minimum radius on the base course.



Remove wings

AB Radius Chart for the Base Course of AB Fieldstone

Wall Height

812 facing unit w/SAU (short anchoring unit) 6° (Ref)	4 ft	6 ft	8 ft	10 ft
	1.2 m	1.8 m	2.4 m	3.0 m
	6 ft 7 in. 2.0 m	7.0 ft 2.1 m	7 ft 5 in. 2.3 m	7 ft 10 in. 2.4 m

The 824 units are to be used in straight walls or gradual curves only. In tight curve transitions, use 812 units only. Use this chart to find the minimum recommended radius at base of wall. Note all lengths, dimensions and setbacks are approximate.



Building with Corners

The built-in corner within the 812 facing units make it easy to create outside corners. One of every four AB Fieldstone facing units double as a corner block, offering a textured side similar to the face.

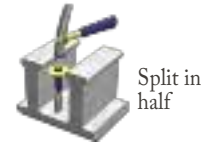

Inside Corners

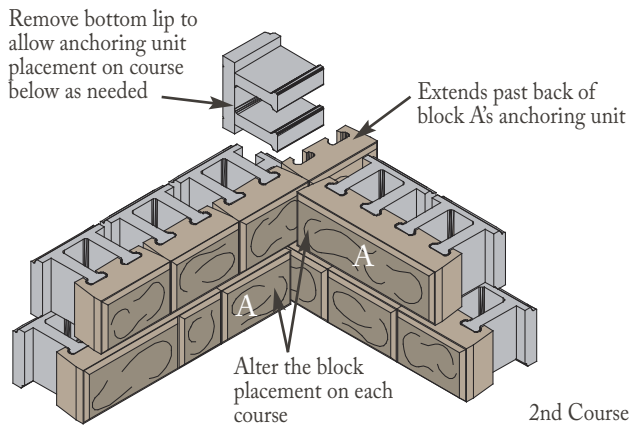
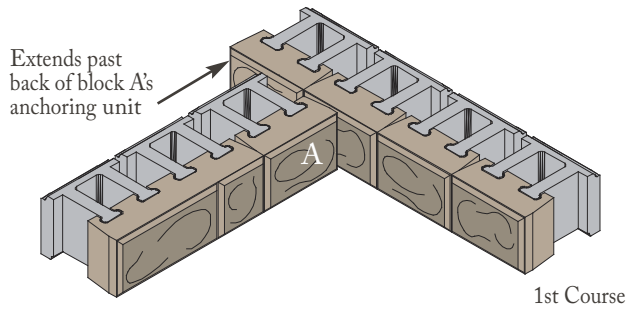

Outside Corners

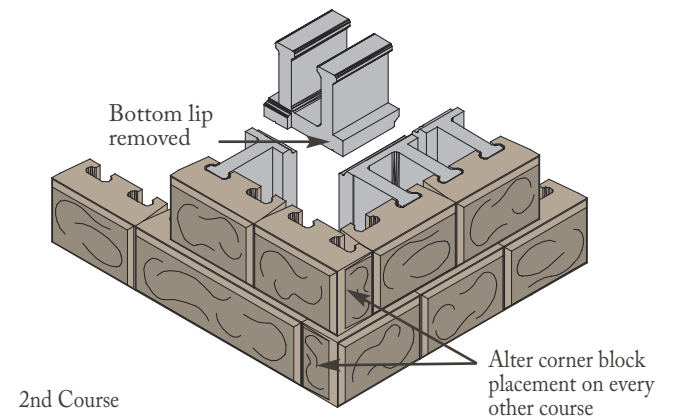
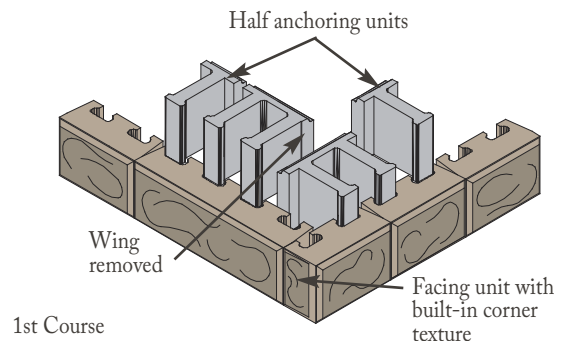

When building corners, modifying the anchoring units will be needed. For inside corners, one anchoring unit on every course starting on the second will need the bottom notch removed. For outside corners, one anchoring unit will need to be split in half and one wing on an additional anchoring unit will need to be removed for each course.

Graphics are to show block placement for application. All retaining wall installations need to include wall rock in cores and behind wall for proper installation.



Installation Basics

Stepping Down / Finishing

Building step downs will require some modifications of two anchoring units per course. A corner facing unit will be needed to create the end of the course. Then a short anchoring unit (SAU) will need to be split and the bottom lip removed on one half and a wing will need to be removed from an additional anchoring unit.

Capping for step downs can be done two different ways. Using the AB Fieldstone cap with and without cutting.

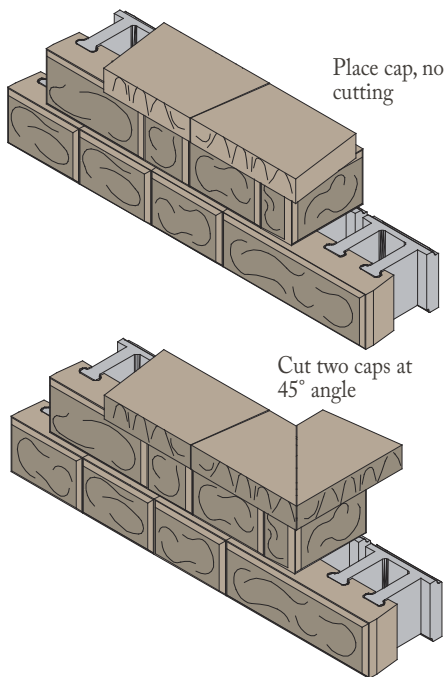
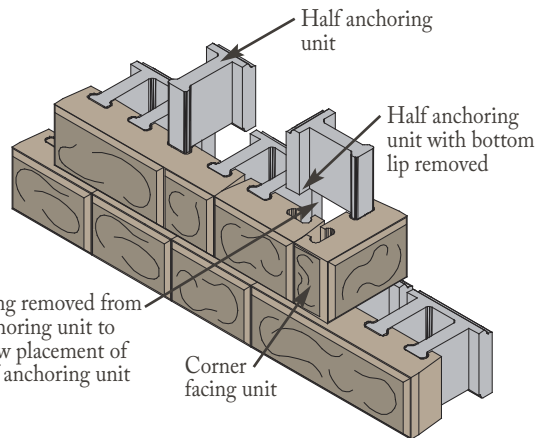

Caps should be installed to overhang the front of the blocks. This accentuates the wall with a nice shadow line.

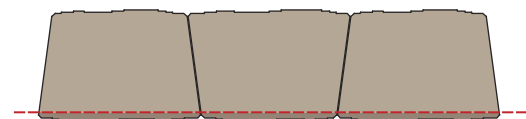
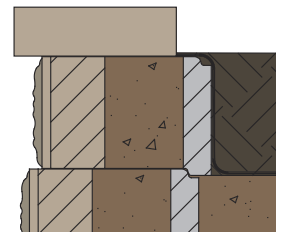

Run a string line to help align caps with overhang.



allanblock.com

Stairs

Stairs can be designed with flowing curves or straight lines. Curved sidewalls create a softer, natural look. Straight sidewalls and corners offer a crisp, traditional style. Building stairs requires careful planning and flexibility and will take extra time to design and build.

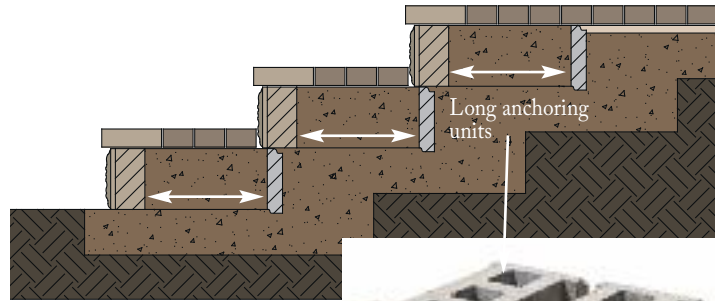

When building stairs, use the long anchoring units (LAU) for the stair risers. This creates a level and stable surface for the treads and additional steps.



Stairways offer a wonderful way to compliment your space and provide elegant transitions through the landscape.



Installation Basics

Parapets

The AB Fieldstone Collection can build beautiful retaining wall structures and is versatile enough with its two-piece design to build free-standing parapets. Using the same product for the retaining wall as well as to finish with a seamless transition into a parapet has never been easier. Parapets can also be built on an existing surfaces as well.

Parapets are constructed using the 812 and 824 facing units along with the AB Dogbone units. AB Dogbone units are half the height of the facing units with two units needed per facing unit for installation. We recommend installing one at the bottom and one at the top of the facing unit with wall rock in between in a staggered fashion.

There are 2 options for building parapet walls:

Standard - AB Dogbones connect the facing units together. This offers the smallest width, and is for straight walls only.

Wider - AB Dogbone units act as anchors in the wall rock allowing any size width to be created. Works well for straight and curved walls.

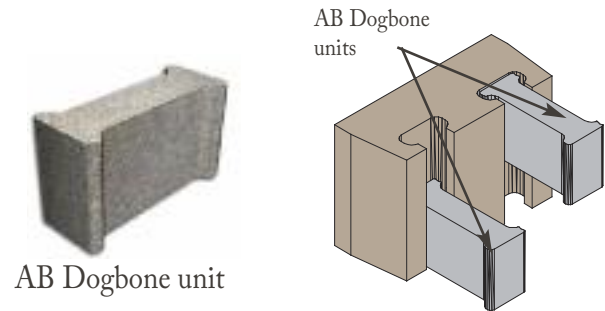
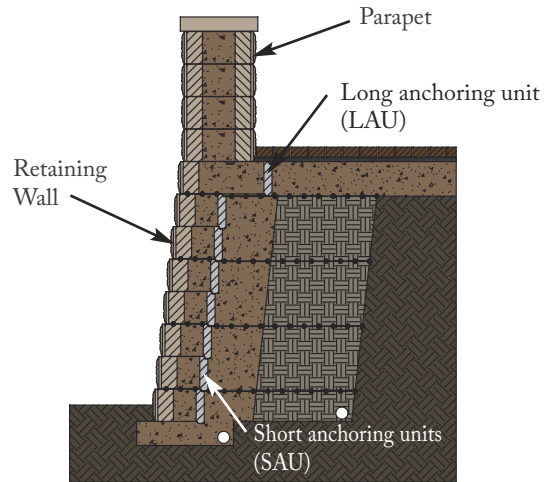

Parapet graphics are to show facing unit and AB Dogbone unit placements. All parapet installations need to include wall rock in cores.

Standard Parapets with Corners

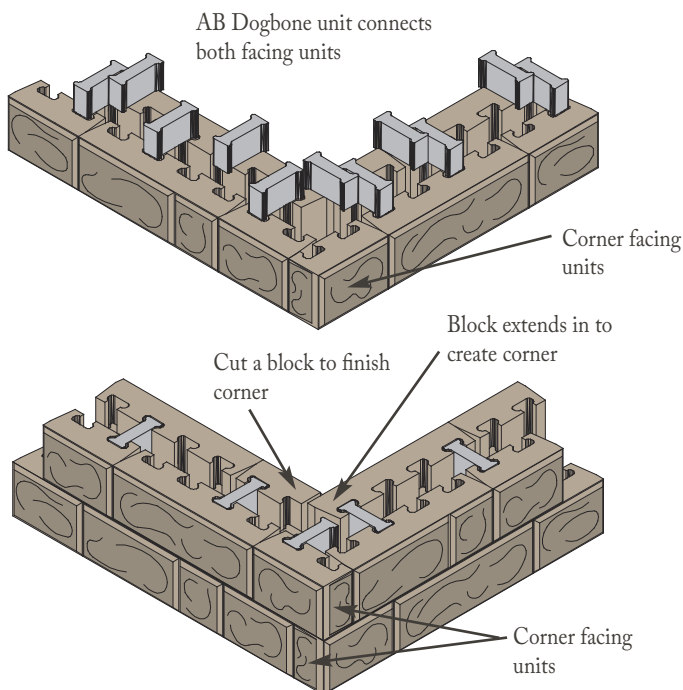

Standard Parapets with Posts

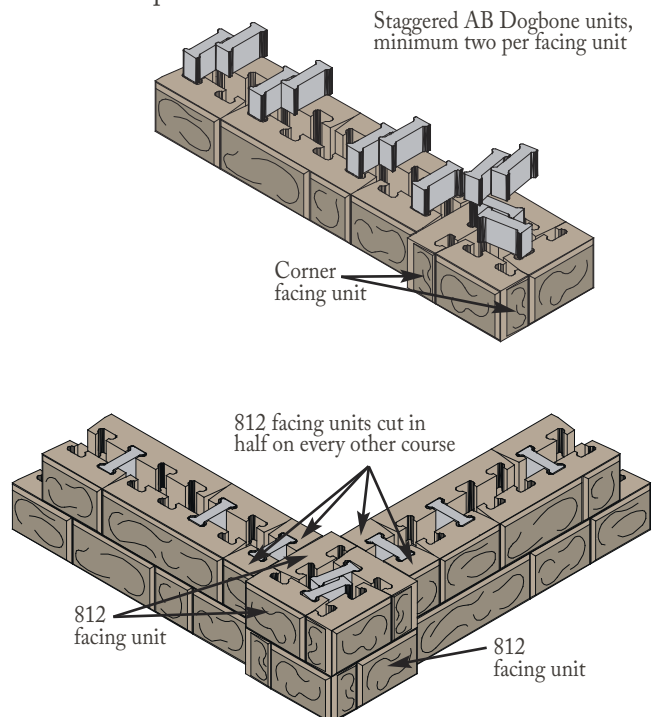

Posts

Standalone posts are built using four corner facing units per course. These blocks have a textured side as well as a face. Wider posts can be built by adding cut or full length 812 facing units between each corner facing unit.

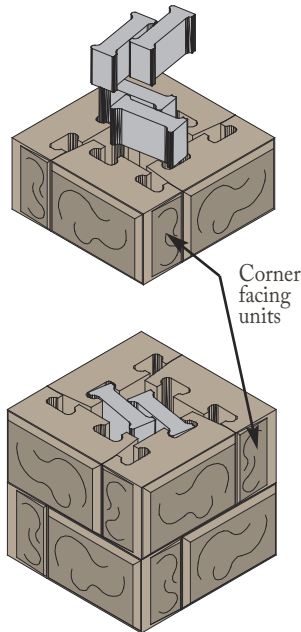

Every facing unit needs to have one AB Dogbone unit to secure in place. Fill posts with wall rock in 4 in. (100 mm) lifts to allow for staggered placement of AB Dogbone units.



Wider Parapets

Building wider parapets will use some of the same installation details as a standard parapet. Depending on the width chosen, cutting a block may be necessary to create the end of a wider parapet.

Wider Parapets - Example 1

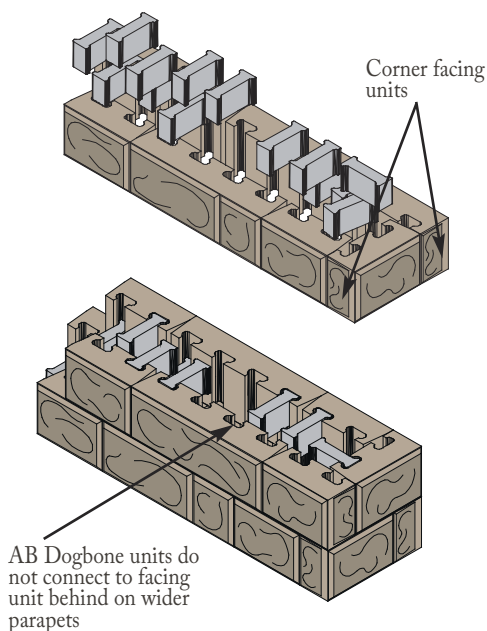

Parapets Post Caps

Finish the post off with two parapet caps for a clean finish.



Parapets can be used to create:

- *Patio Enclosures*
- *Fencing*
- *Planters*

Wider Parapet - Example 2

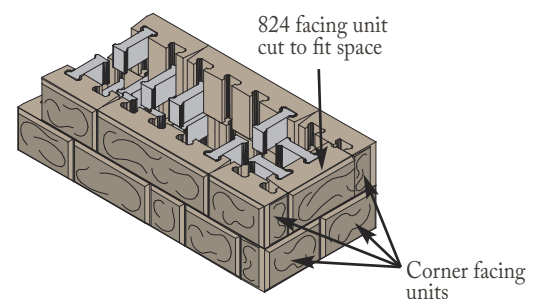

Parapet graphics are to show facing unit and AB Dogbone placements. All parapet installations need to include wall rock in cores.

Installation Basics

Wider Parapets with Corners

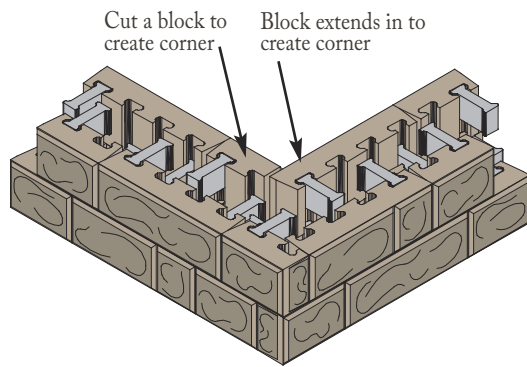
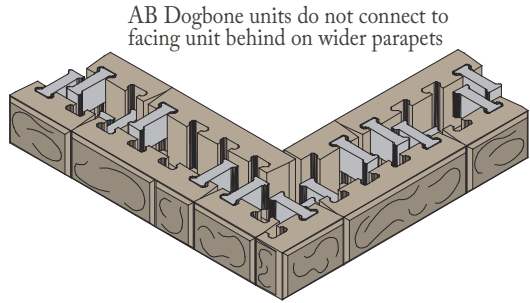

Stagger the AB Dogbone units, one up and one down with the facing units to ensure each facing unit has two AB Dogbones securing it in place for every course. When building corners, a block will need to be cut for each course.

Curved Parapets

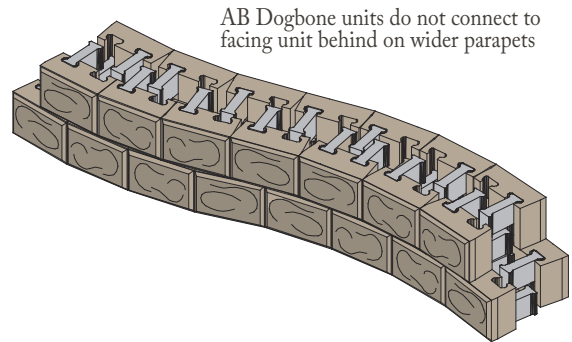
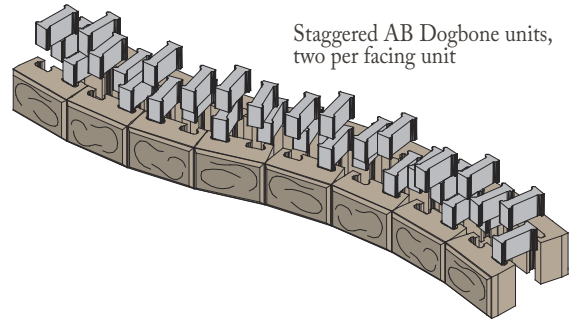

Parapet graphics are to show facing unit and AB Dogbone placements. All parapet installations need to include wall rock in cores.



When capping parapets many different materials can be used from natural stone or paving slabs. Visit your local AB Dealer to see what options are available for capping, once the parapet width has been determined. We always recommend that the cap overhangs the wall below to create a nice shadow line.

Product and Estimating



allanblock.com

AB Fieldstone Collection®



812 facing unit with SAU
 Approx. 1.5 blk/ft² (16 blk/m²)
 8 in. H x 13 in. D x 12 in. L
 (200 mm H x 330 mm D x 300 mm L)
 60 lbs (30 kg)



824 facing unit with SAU
 Approx. 0.75 blk/ft² (8 blk/m²)
 8 in. H x 13 in. D x 24 in. L
 (200 mm H x 330 mm D x 600 mm L)
 125 lbs (55 kg)



812 facing unit with LAU
 Approx. 1.5 blk/ft² (16 blk/m²)
 8 in. H x 23 in. D x 12 in. L
 (200 mm H x 585 mm D x 300 mm L)
 90 lbs (40 kg)



824 facing unit with LAU
 Approx. 0.75 blk/ft² (8 blk/m²)
 8 in. H x 23 in. D x 24 in. L
 (200 mm H x 585 mm D x 600 mm L)
 185 lbs (85 kg)



AB Dogbone - Parapets
 4 in. H x 7 in. D x 2.5 in. L
 (100 mm H x 175 mm D x 60 mm L)
 5 lbs (2 kg)



AB Fieldstone Cap
 3.5 in. H x 11.5 in. D x 17.5 and 14.5 in. L
 (90 mm H x 300 mm D x 450 and 350 mm L)
 55 lbs (25 kg)

Specifications are approximate, contact local representative for availability, exact specifications, sizes and colors for all Allan Block products.



AB Fieldstone Parapet Cap
 3.5 in. H x 18 in. D x 17.5 and 24 in. L
 (90 mm H x 460 mm D x 600 mm L)
 80 lbs (36 kg)

Download our Estimating App



- Browse Through the Photo Gallery
- Check out the Featured Projects
- Estimate Your Retaining Wall Project
- Receive a Complete Material List and Project Layout

AB Fieldstone Collection®

Approx. number of 812 facing units needed

Approximate Wall Height	Wall Length					
	5 ft 1.5 m	10 ft 3.0 m	20 ft 6.0 m	30 ft 9.0 m	40 ft 12.0 m	50 ft 15.0 m
1 course 8 in. (200 mm)	5	10	20	30	40	50
2 courses 16 in. (400 mm)	10	20	40	60	80	100
3 courses 24 in. (600 mm)	15	30	60	90	120	150
4 courses 32 in. (800 mm)	20	40	80	120	160	200
5 courses 40 in. (1.0 m)	25	50	100	150	200	250
6 courses 48 in. (1.2 m)	30	60	120	180	240	300

To switch AB Fieldstone 824 facing units, simply divide the number shown above in half.

Capstones	4	8	15	23	30	38
-----------	---	---	----	----	----	----

Note: Capstones add 3.5 in. (90 mm) to your total wall height. For any posts in the design, 2 AB Fieldstone Parapet Caps will be needed per post.

More Products from Allan Block

AB® Collection



AB Stones or AB Classic
Approx. 1 blk/ft² (11 blk/m²)
8 in. H x 12 in. D x 18 in. L
(200 mm H x 300 mm D x 460 mm L)
75 lbs (34 kg)



AB Jumbo Junior
Approx. 2 blk/ft² (22 blk/m²)
8 in. H x 9.5 in. D x 9 in. L
(200 mm H x 240 mm D x 230 mm L)
35 lbs (16 kg)



AB Lite Stone
Approx. 2 blk/ft² (22 blk/m²)
4 in. H x 12 in. D x 18 in. L
(100 mm H x 300 mm D x 460 mm L)
35 lbs (16 kg)



AB Junior Lite
Approx. 4 blk/ft² (44 blk/m²)
4 in. H x 12 in. D x 9 in. L
(100 mm H x 300 mm D x 230 mm L)
18 lbs (8 kg)

The AB Collection gives a smooth fluid finish to any outdoor living space. Use the blocks individually or blend them together to create patterned walls that will define your space for years to come. Enjoy the beauty and durability of this collection's classic cut stone look that adds distinguished style to any landscape.



More Products from Allan Block



allanblock.com

AB Europa® Collection



AB Dover
Approx. 1 blk/ft² (11 blk/m²)
8 in. H x 10.5 in. D x 18 in. L
(200 mm H x 265 mm D x 460 mm L)
80 lbs (36 kg)



AB Palermo
Approx. 2 blk/ft² (22 blk/m²)
8 in. H x 9.5 in. D x 9 in. L
(200 mm H x 240 mm D x 230 mm L)
35 lbs (16 kg)



AB Barcelona
Approx. 2 blk/ft² (22 blk/m²)
4 in. H x 10.5 in. D x 18 in. L
(100 mm H x 265 mm D x 460 mm L)
40 lbs (18 kg)



AB Bordeaux
Approx. 4 blk/ft² (44 blk/m²)
4 in. H x 10.5 in. D x 9 in. L
(100 mm H x 265 mm D x 230 mm L)
20 lbs (9 kg)

The AB Europa Collection captures the hand-laid stone effect that brings distinction to any project. The blocks can be used separately or blended together for outstanding results. The unique texture creates a stunning look and gives old world charm to any landscape.



More Products from Allan Block

AB Courtyard Collection®



AB Dublin
Approx. 1.5 blk/ft² (16 blk/m²)
6 in. H x 7 in. D x 16.5 in. L
(150 mm H x 175 mm D x 420 mm L)
39 lbs (18 kg)



AB York
Approx. 3 blk/ft² (32 blk/m²)
6 in. H x 7.0 in. D x 9.0 & 7.5 in. L
(150 mm H x 175 mm D x 230 & 190 mm L)
20 lbs (9 kg)



AB Corner Block
6 in. H x 7 in. D x 15.5 & 15 in. L
(150 mm H x 175 mm D x 400 & 380 mm L)
42 lbs (19 kg)



AB Wall Cap
3.5 in. H x 10 in. D x 9.25 & 7 in. L
(90 mm H x 250 mm D x 235 & 175 mm L)
22 lbs (10 kg)



AB Post Cap
3 in. H x 12 in. D x 24 in. L
(75 mm H x 305 mm D x 610 mm L)
70 lbs (32 kg)

The AB Courtyard Collection is a durable, versatile and a cost-effective way to bring value into your landscaping. This two-sided free standing wall system's unique design can be used in many different applications. Define your space into usable outdoor rooms; add charm to a garden with firepits or water features, create custom kitchens within your patio to enhance your backyard masterpiece.



More Products from Allan Block



allanblock.com

AB Fence®



AB Fence Post Block
Approx. 1.5 blk/ft² (5 blk/m of post height)
8 in. H x 12 in. D x 18 in. L
(200 mm H x 305 mm D x 460 mm L)
75 lbs (35 kg)



AB Fence Half Panel Block
Approx. 2 blk/ft² (22 blk/m²)
8 in. H x 6 in. D x 9 in. L
(200 mm H x 150 mm D x 230 mm L)
25 lbs (10 kg)



AB Corner Block
Approx. 1.5 blk/ft² (5 blk/m of post height)
8 in. H x 12 in. D x 12 in. L
(200 mm H x 305 mm D x 305 mm L)
50 lbs (25 kg)



AB Cap Block
5 in. H x 12 in. D x 18 in. L
(130 mm H x 305 mm D x 460 mm L)
60 lbs (30 kg)



AB Fence Panel Block
Approx. 1 blk/ft² (11 blk/m²)
8 in. H x 6 in. D x 18 in. L
(200 mm H x 150 mm D x 460 mm L)
50 lbs (25 kg)



AB Fence Lite Panel Block
Approx. 2 blk/ft² (22 blk/m²)
4 in. H x 6 in. D x 18 in. L
(100 mm H x 150 mm D x 460 mm L)
25 lbs (10 kg)



AB Fence Half Lite Panel Block
Approx. 4 blk/ft² (44 blk/m²)
4 in. H x 6 in. D x 9 in. L
(100 mm H x 150 mm D x 230 mm L)
13 lbs (5 kg)

The AB Fence System uses posts and panels like many typical fence systems to construct beautiful and durable concrete structures that will stand the test of time. The architectural look of the AB Fence evokes the feeling of stability and quality while also providing privacy, security and sound abatement, making the AB Fence System the product of choice.

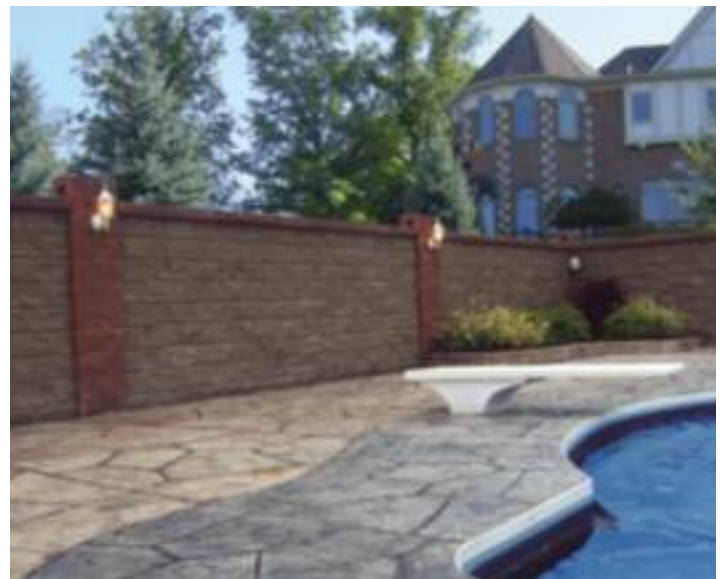

Allan Block

#AlwaysBetter

Visit allanblock.com for complete information on all of the Allan Block products.

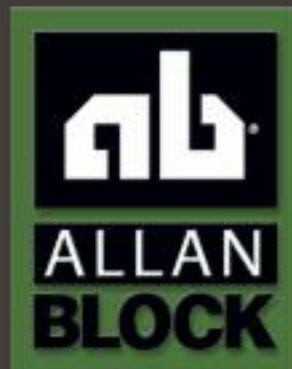

allanblock.com

